



RipEX Hot Standby

- Two hot-stand-by standard RipEX units inside
- Each unit powered by independent power supply (100-240 VAC or 36-60 VDC)
- Automatic changeover in case of failure
- Switch-over time < 2 s
- Auto toggle mode
- 4x HW alarm output
- Internal fans
- Back-up Battery pack
- 19" rack 3U

General

RipEX-HS is designed to be used at **critical sites**, where high HW **reliability** is required – typically **master** or **repeater** stations.

RipEX-HS is assembled with 2 standard **RipEX** units, each powered by its **independent** power supply. A controller takes care of automatic changeover in case of failure. Changeover conditions are widely configurable. Since both units are hot-stand-by and use identical MAC addresses, **exceptional switch-over time** of less than 2s is achieved.

LED panels, Mode buttons, HW alarm outputs, SNMP traps and standard **RipEX** units inside makes **RipEX-HS** configuration and control quite easy and maintenance can be done by anyone familiar with RipEX.

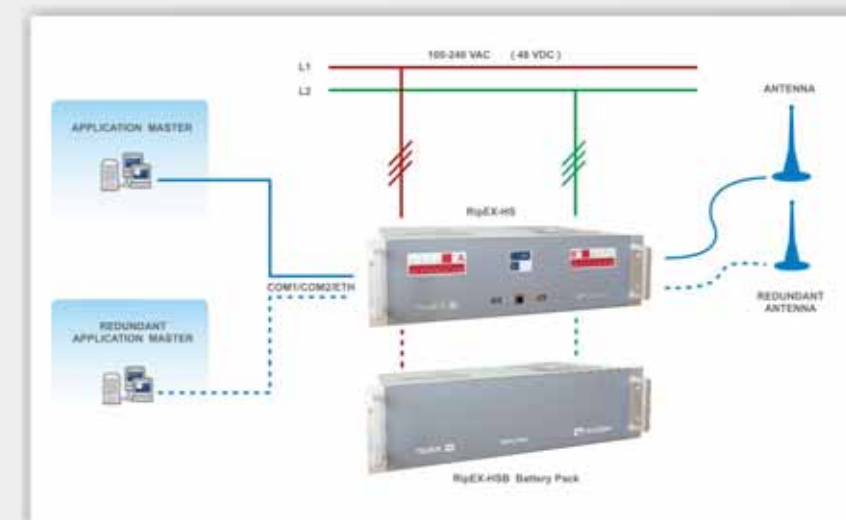

Applications

- Central sites
- Repeaters
- Important remote sites

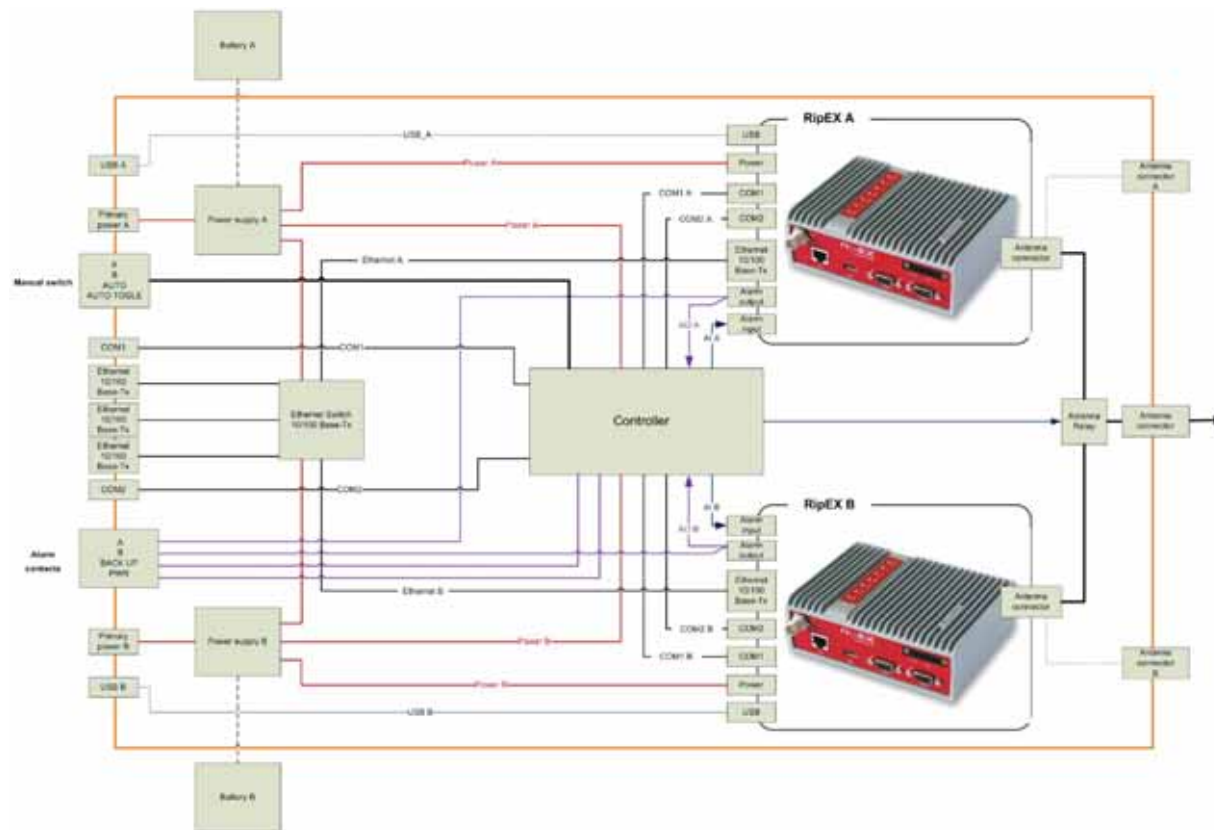

Technical parameters

Radio parameters

The same as RipEX units used

Hot Standby

Switch-over time < 2 s

Electrical

Primary power	HW models: 100-240 V AC 50-60 Hz 36-60 VDC, positive grounding possible
RipEX-HSB	Battery pack Output 2 x 24 V / 7,2 Ah

Interfaces

Ethernet	3x switched 10/100 Base-T Auto MDI/MDIX, RJ45
COM 1	RS232, DB9F, 300-115 200 bps
COM 2	RS232/RS485 SW configurable, DB9F, 300-115 200 bps
USB	2x USB 1.1 for each RipEX unit, Host A
Antenna	50 Ohms, N-female(s)
HW models (according to Antenna)	
	1x N-female – Rx/Tx, switched
	2x N-female – Rx/Tx, separate for each RipEX unit
	2x N-female – separate Rx and Tx, switched
	4x N-female – separate Rx and Tx, separate for each RipEX unit

Mechanical

Dimensions	19" rack 3U 482 W x 401 D x 133 H mm (18,98 x 15,79 x 5,24 in)
Weight	7.1 kg (15.7 lbs), RipEX unit excl. 9.1 kg (20.1 lbs), RipEX unit incl.

Environmental

IP Code (Ingress Protection)	IP20
MTBF (Mean Time Between Failure)	> 100 000 hours
Operating temperature	-10 to +60 °C (14 to 140 °F)
Humidity	5 to 95% non-condensing
Storage	-40 to +85 °C (-40 to +185 °F) 5 to 95 % non-condensing

Diagnostic and Management

Standard for individual RipEX used	
LED panels for each RipEX unit:	standard RipEX LED panel (7x tri-color LEDs: Power, ETH, COM1, COM2, Rx, Rx, Status)
for each RipEX unit:	+ 4x two-color LEDs: Active, Power supply, Battery, Alarm
HW Alarm outputs	RipEX A, RipEX B, Switch, Power

Approvals

CE, FCC

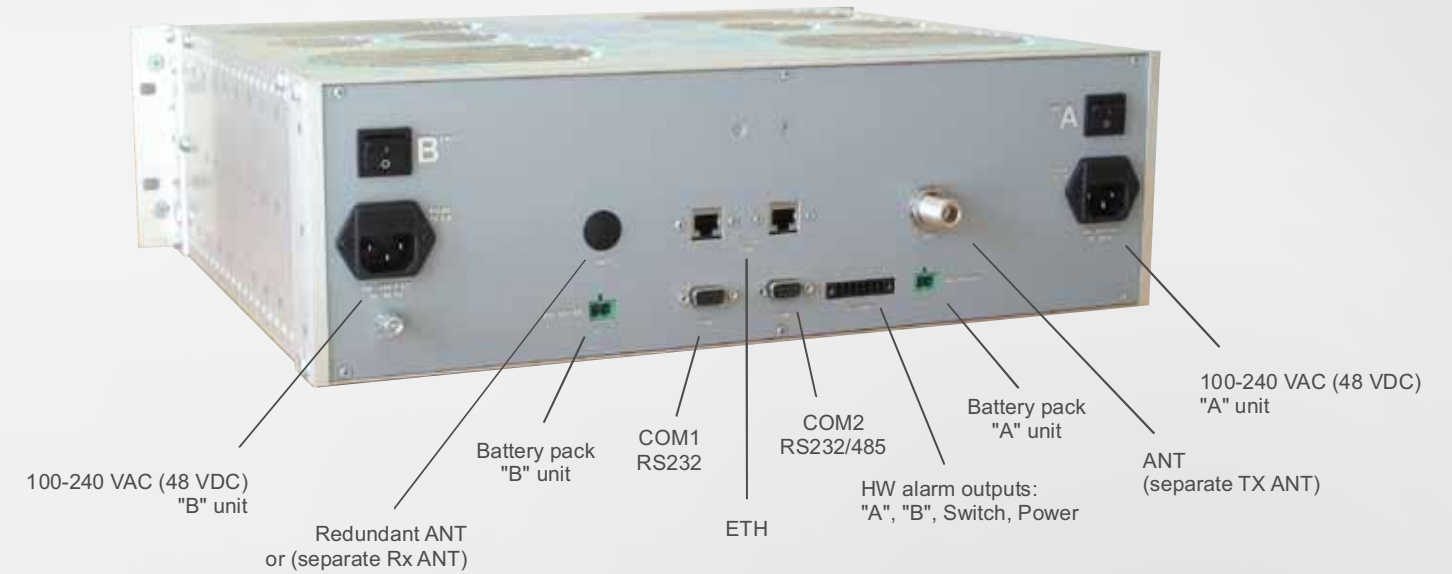

Functionality

There are 2 standard RipEX units with identical configurations inside of RipEX-HS. Both units are booted, however only one is active. The interfaces (COM1, COM2, Ethernet, Radio) of second unit are disconnected.

When the active unit HW alarm output changes to "On" (when a controlled value exceeds the respective threshold), the controller automatically switches all interfaces (COM1, COM2, ETH, ANT - if applicable) to the second unit and it takes over all functions. Since both units are using the same MAC addresses (MAC cloning), there is a minimal drop-out while switching, less than 2 s.

Possible controlled values are: RSS, DQ, TXLost[%] - lost packets on Radio channel, Ucc - power voltage, Inside temperature, RF power, VSWR, ETH[Rx/Tx], COM1[Rx/Tx], COM2[Rx/Tx], SNMP trap with each switch-over can be sent (depending on configuration) to central SNMP management.

Operating modes



- **Auto** – primary active is RipEX „A“, when it fails, controller automatically switches-over to RipEX „B“



- **Auto toggle** – the same as Auto mode, in addition after set time controller automatically switches-over to RipEX „B“, even if „A“ doesn't have any alarm and uses „B“ for set period in order to confirm, that RipEX „B“ is fully ready-to-operate



- **A** – only RipEX „A“ is active and controller will never switch to RipEX „B“



- **B** – only RipEX „B“ is active and controller will never switch to RipEX „A“

Reliability

- Every single unit **tested in a climatic chamber** as well as in real traffic
- **Heavy-duty industrial components**
- Industrial rugged case
- -10 to +60 °C (14 to 140 °F)
- Internal fans (automatically start-up when temperature exceeds 50 °C)
- **3 years warranty**

HW alarm outputs

- **4 HW alarm outputs** available on the screw terminal connector on the rear panel
- Standard RipEX HW alarms of units „A“ and „B“
- Switch HW alarm informs of active unit failure and controller switch-over to the back-up unit
- Power alarm informs of controller board power drop-out

Antennas

- By default **one antenna** connector connected to active unit Available model with **separate „A“ and „B“** antenna connectors when **redundant** antennas are used
- When RipEXes with **separated Rx and Tx antenna** connectors are used, both respective models are available too.

Easy to configure and maintain

- Front panel:
 - **4 buttons for Operating mode settings**
 - Ethernet
- **Individually for each unit:**
 - Standard RipEX LED panels
 - Next LED's (Active, Power supply, Battery, Alarm)
 - USB for service access
- All the other connectors are on the rear panel
- All SW settings are available via standard RipEX web

Power supply

- **2 power supplies, independently for „A“ and „B“ units**
- Independent power connectors, switches and fuses on rear panel
- Possibility to use different input power phases in order to increase reliability

Battery back-up

- **“RipEX-HSB – Battery pack” available**
- Separate batteries for RipEX „A“ and „B“
- Batteries are charged-up from RipEX-HS
- Individual 19" rack 3U box
- Space for 4x 12 V / 7,2 Ah, FASTON.250 (6,3 mm) batteries
- Approx. **10 hours** of RipEX-HS operation